

# IMPACDOR®

## FS-250

Food Service • Restaurants • Retail Stores • Commercial Applications • Light Hand Carts & Pallets

**The Aleco ImpacDor® FS-250** is a lightweight, durable and economical 1/4" (6mm) ABS door with reinforced spine that provides exceptional strength and longevity.

The Aleco ImpacDor® FS-250 is a double-acting door designed for food service, restaurant, retail and light handcart and pallet applications where an attractive, durable and affordable traffic door is needed. The solid ABS door-body is impenetrable to moisture, food stains and common chemicals. Drips, spills and smears simply wipe off, leaving a clean surface.



### Unique design eliminates chipping and peeling

The Aleco ImpacDor® FS-250 is a one-piece solid-core door without gasketing. The flexibility of the door allows it to function well even in high cart and personnel traffic areas. The facing will not chip, peel or corrode, even with repeated impact by carts, hand truck and pallets. The color of the door is consistent throughout the material for an attractive long-lasting appearance.

### The FS-250 opens quick and easily with EZ hinge hardware

With the EZ hinge system, the FS-250 operates smoothly and quietly, and includes 8-3/4" high jamb guards. Easy-to-open doors will translate to longer lasting doors and safer personnel and product passage. FS-250 doors open 125 degrees in each direction to accommodate the natural flow of traffic.



### EZ Hinge

#### 5-YEAR WARRANTY

(Limited warranty. Contact your Aleco representative for details.)

### Custom made to exact size

Most Aleco doors are made to exact size specifications to fit existing door openings. For consistent performance, sizes are customized to 1/8" on every FS-250 door to fit perfectly.



**FS-250**

**FS-250 Features:**

- Rugged 1/4" (6mm) ABS construction with reinforced spine
- Zinc plated mounting hardware (Stainless Steel upgrade available)
- Easy installation
- Light, responsive swing action accommodates personnel, carts and racks up to moderate pallet jack traffic

**Options:**

- Choice of decorative colors: *Cloud Gray, Charcoal Gray, Black, Cadet Blue, Cocoa, Chocolate, Beige, Red, White, Royal Blue and Green*
- ABS & stainless steel pad style impact wear panels any height up to 48"
- Vision panels in various sizes and styles



Frame not included but available as an option.

**FS-250 Door Specifications**

**Mounting Hardware**

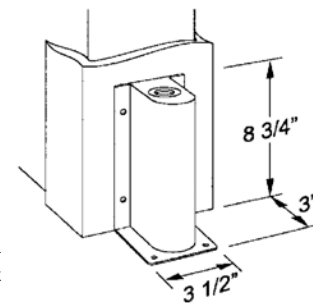
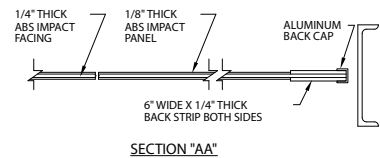
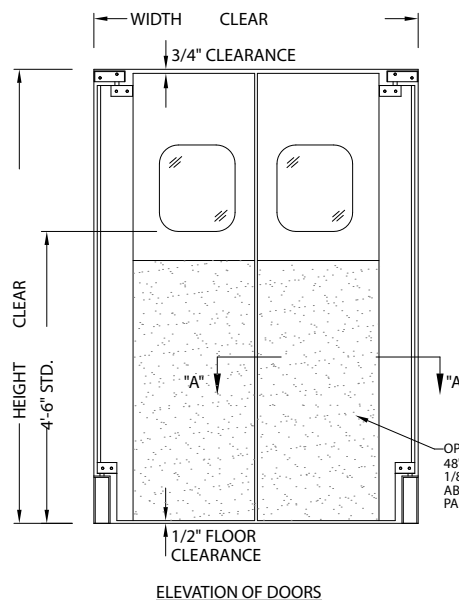
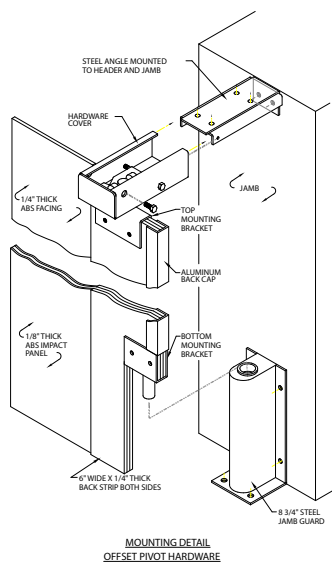

**Standard Jamb Guard:**  
8 3/4" Zinc Plated Jamb Guard for EZ Hinge Hardware

